

P. C. B. LAYOUT

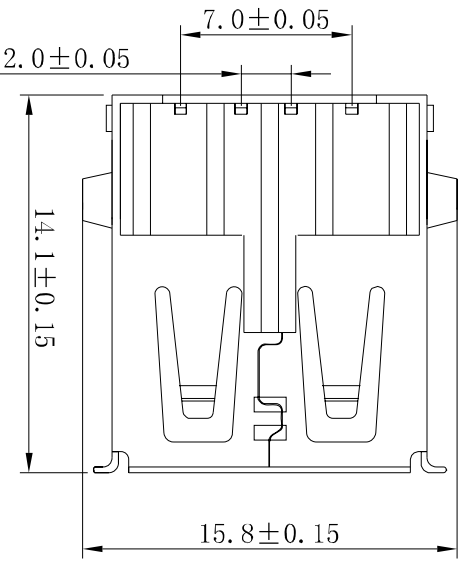

ELECTRICAL CHARACTERISTICS:  
 CURRENT-MAX (AMPS) 1.0A  
 VOLTAGE-MAX (VOLTS) 30V  
 WITHSTANDING VOLTAGE 750V AC  
 CONTACT RESISTANCE (OHMS) 30 MILLIOHMS MAX  
 INSULATION RESISTANCE (OHMS) 1000 MEGOHMS MIN  
 TEMPERATURE RANGE 5° C +40° C  
 MATERIAL:  
 CONTACTS COPPER ALLOY  
 INSULATOR PBT+30%G.F. UL 94V-0  
 SHELL BRASS  
 PLATING:  
 CONTACTS GOLD FLASH AND NICKEL PLATED  
 SHELL NICKEL OF TIN PLATED

UNITS:		<b>CSCONN</b>		CSCONN PRECISE ELECTRONICS CO.,LTD	
GENERAL TOLERANCE		PART NO.(INTENDED USE)		TITLE:	
X. ° ±5°	0.X ±0.3	CUS-04132F-D90		USB A/F 4P DIP 90°	
X.1 ±2°	0.XX ±0.2	APPD:		DWG NO.	
X.X ±1°	0.XXX ±0.1	CHKD: Skilla		SCALE	
XXX. ±0.5°		DR: Killy		1:1	
				SHEET	
				1 OF 1	
				REV	
				A	