

PCB LAYOUT

Specifications:
 Electrical:
 Contact Resistance 30 milliohms MAX
 Dielectric Withstanding Voltage: 500 V AC AT Sea Level
 Insulation Resistance: 1000 MEGA ohms MIN
 Mechanical:
 Mating Force: 3.5 KG MAX
 Umating Force: 0.7 KG MIN.

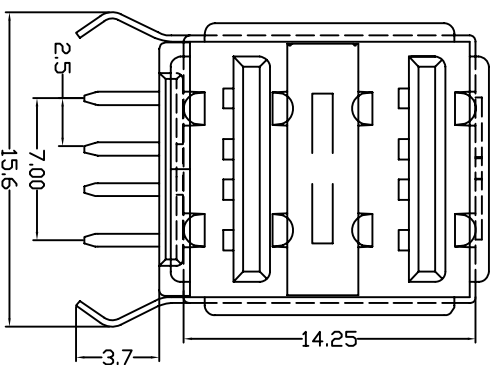

NO.	PARTS	MATERIAL	QTY.	FINISHING
5	HOUSING	WHITE PBT	1	UL 94V-0
4	COVER SHELL	STEEL	1	PLATED NI
3	Mod Clip Slice	STEEL	1	PLATED NI
2	SHELL	STEEL	1	PLATED NI
1	TERMINAL	BRASS	8	Plated Gold in Mating Area Tin/ On Solder pads

CSCONN

CSCONN PRECISE ELECTRONICS CO.,LTD

UNITS:		TITLE:		SCALE		SHEET		REV	
GENERAL TOLERANCE		PART NO.(INTENDED USE)		DWG NO.		1 OF 1		A	
X. ° ±5°	0.X ±0.25	C/S-0413142F-D90		USB A/F 8P D1P90 双层半包		1:1		A	
X.1 ±2°	0.XX ±0.2	APPD:		USB					
XX. ±1°	0.XXX ±0.1	CHKD: Skila							
		DR: Kitty							

