

PCB LAYOUT TOP VIEW

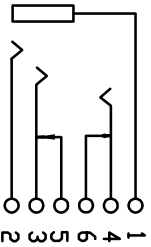
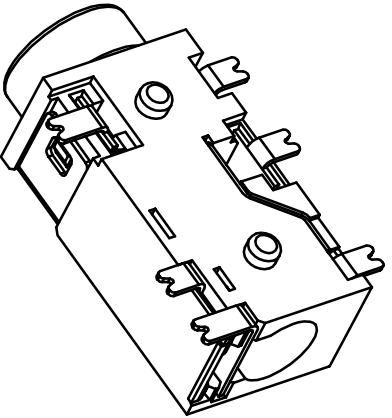

CIRCUIT DIAGRAM

- SPECIFICATIONS:
1. CURRENT RATING: DC 30V 0.5A.
 2. CONTACT RESISTANCE: 30mΩ MAX.
 3. INSULATION RESISTANCE: 100MΩ MIN AT 500V DC.
 4. WITHSTAND VOLTAGE: AC 500V/1 MINUTE.
 4. OPERATING TEMPERATURE RANGE: -25°C TO +85°C.
 5. INSERTION FORCE: 3N-30N.
 6. EXTRACTION FORCE: 3N-30N.
 7. LIFE TEST: 5000 CYCLES.

No.	PART NAME	QTY	MATERIAL (THICK, COLOR)	REMARK
①	HOUSING	1	PA-9T (Black)	
②	TERMINAL	1	PHOSPHOR BRONZE t=0.20	Ag-Plated
③	TERMINAL	1	PHOSPHOR BRONZE t=0.20	Ag-Plated
④	TERMINAL	1	PHOSPHOR BRONZE t=0.20	Ag-Plated
⑤	TERMINAL	1	PHOSPHOR BRONZE t=0.20	Ag-Plated
⑥	TERMINAL	1	BRASS t=0.20	Ag-Plated
⑦	TERMINAL	1	PHOSPHOR BRONZE t=0.20	Ag-Plated

UNITS: mm

GENERAL TOLERANCE

X ±.5° 0.X±0.25

X.1±.2° 0.XX±0.2

XX ±.1° 0.XXX±0.1

CSCONN

CSCONN PRECISE ELECTRONICS CO.,LTD

PART NO.(INTENDED USE)
CPJ3537455

TITLE: PHONE JACK

APPD: Sk1a

DWG NO. JACK

CHKD: Kitty

SCALE SHEET REV

DR: Kitty

1:1 1 OF 1 A