

- SPECIFICATION**
1. Rating : DC 30V 0.5A;
  2. Contact resistance:  $\leq 0.03\Omega$ ;
  3. Insulation resistance:  $\geq 100M\Omega$  (DC250V);
  4. Withstand voltage: 500VAC ;
  5. Insertion and extraction force: 3-20N;
  6. Life test: 5,000 cycles.

**P.C.B LAYOUT  
TOP VIEW**

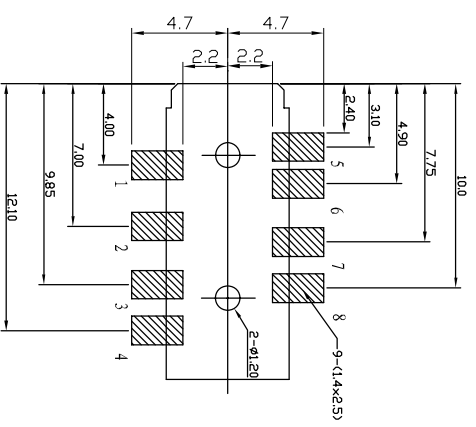

**SCHEMATIC**

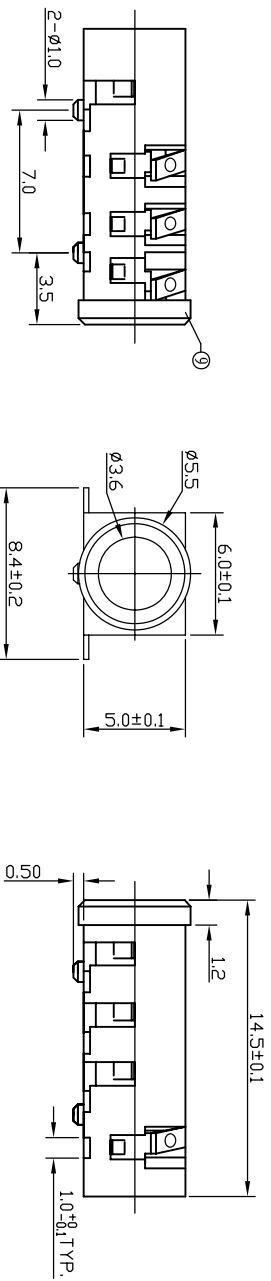
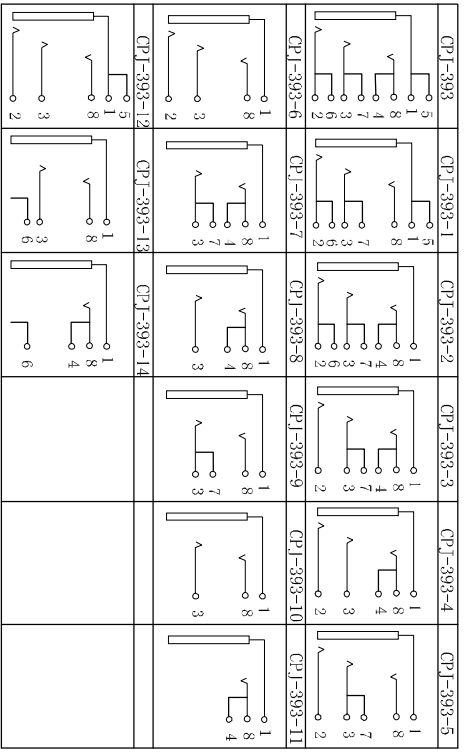

NO.	DESCRIPTION	QTY	MATERIAL	PLATING
9	HOUSING	1	PA46	
8	2#CONTACT FOOT	1	BRONZE	Ag-Plating
7	1#CURVE PIECE	1	BRASS	Ag-Plating
6	1#CURVE PIECE	1	BRASS	Ag-Plating
5	2#CURVE PIECE	1	BRASS	Ag-Plating
4	1#CURVE PIECE	1	BRASS	Ag-Plating
3	1#CONTACT FOOT	1	BRONZE	Ag-Plating
2	1#CONTACT FOOT	1	BRONZE	Ag-Plating
1	1#CONTACT FOOT	1	BRONZE	Ag-Plating

**UNITS:** mm  
**GENERAL TOLERANCE**  
 X.° ±5° 0.X±0.3  
 X.1±2° 0.XX±0.2  
 XX.±1° 0.XXX±0.1  
 XXX.±0.5°

**CSCONN**  
 PART NO.(INTENDED USE)  
 CPJ-393

SHENZHEN CSCONN PRECISE ELECTRONICS CO.,LTD  
**TITLE:** PHONE JACK

**DWG. NO.** JACK

<b>APPD:</b>	SKiIa	<b>SCALE</b>	1:1	<b>SHEET</b>	1 OF 1	<b>REV</b>	A
<b>CHKD:</b>	SKiIa						
<b>DR:</b>	Kitty						