

P. C. B LAYOUT
TOP VIEW

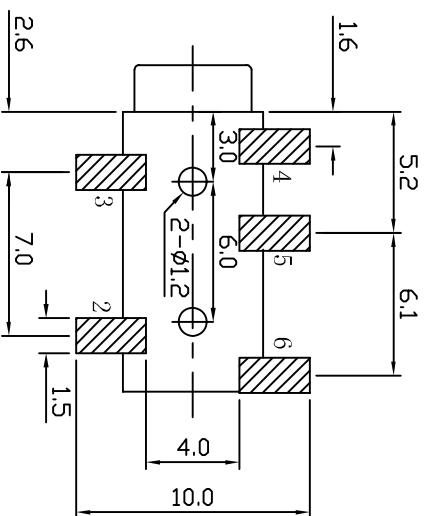

SPECIFICATION

1. Rating : DC 30V 0.5A;
2. Contact resistance: $\leq 0.03\Omega$;
3. Insulation resistance: $\geq 100M\Omega$ (DC250V) ;
4. Withstand voltage: 500VAC ;
5. Insertion and extraction force: 3-20N;
6. Life test: 5,000 cycles.

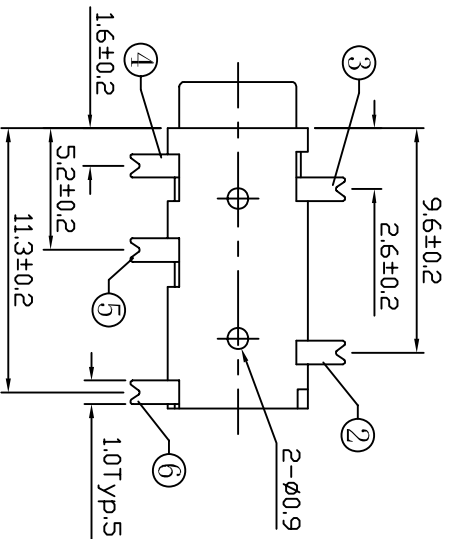

SCHEMATIC

CPJ-327A	CPJ-327A-2	CPJ-327A-3	CPJ-327A-4	CPJ-327A-5	CPJ-327A-6

NO.	DESCRIPTION	QTY	MATERIAL	PLATING
6	CURVE PIECE	1	BRASS	Au/Ag-Plating
5	3#CONTACT FOOT	1	Be-Cu	Au/Ag-Plating
4	2#CONTACT FOOT	1	Be-Cu	Au/Ag-Plating
3	1#CONTACT FOOT	1	Be-Cu	Au/Ag-Plating
2	SPRING	1	Be-Cu	Au/Ag-Plating
1	HOUSING	1	PA46	

CSCONN

SHENZHEN CSCONN PRECISE ELECTRONICS CO.,LTD

PART NO.(INTENDED USE)

CPJ-327A

TITLE: PHONE JACK

DWG NO. JACK

JACK

APPD:

SKID: Skilla

SCALE

1:1

CHKD:

DR: Kitty

SHEET

1 OF 1

REV

A

E

D

C

B

A

1 2 3 4 5 6 7 8